

Product Note 8508-1

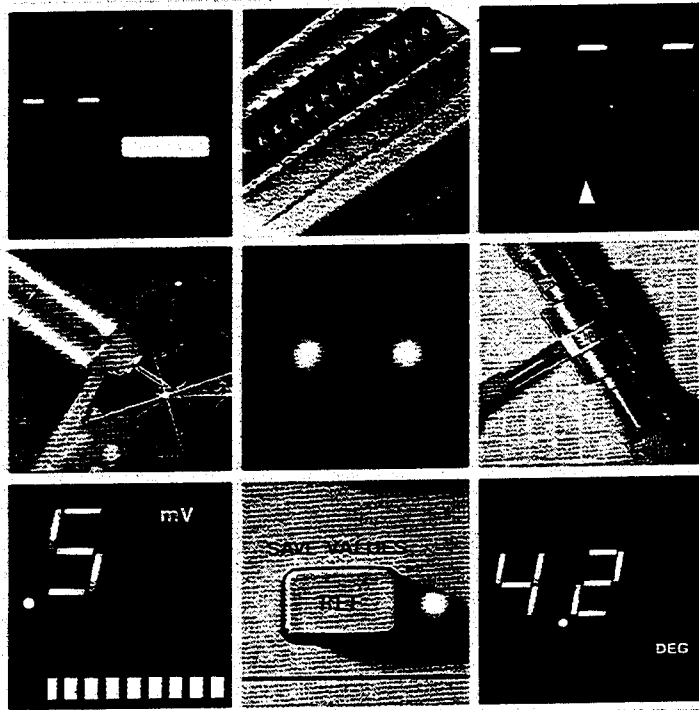

HP 8508A Vector Voltmeter User's Guide

ADKY





Don't zap your input probes!

The probes of the HP 8508A are susceptible to damage from electro-static discharge (ESD). Comply with the following precautions to help avoid damage to your probes.

Anti-static precautions

Never touch the tip of the probe.

Eliminate ESD on the body by wearing a snug-fitting ground strap that is connected to earth ground through a 1M ohm resistor.

Eliminate ESD on the work surface by using a grounded anti-static bench mat. Optional floor mats provide an extra measure of protection especially in areas with floor carpet. Never use this product on a carpeted work surface unless the carpet is of a conductive type specifically designed to eliminate ESD.

Do not introduce ESD into the Device Under Test (DUT) while using the probes. If an unprotected person touches a part of the DUT, a static surge could damage the DUT as well as the probes.

Always refit the protective cover when the probe is not in use.

Mechanical abuse

The tips of the probes are fragile and can break if the probe is dropped.

Table of Contents

Section 1	Introduction	Page 3
	What is the HP 8508A, what you can measure, other equipment	
Section 2	Getting Started	Page 5
	Front panel operation, connection diagram, simple measurement example	
Section 3	Basic measurements	Page 9
	Probe measurements, 50ohm measurements	
Section 4	Advanced measurements	Page 13
	Transmission, reflection, other functions	
Section 5	Automatic measurements	Page 17
Appendix A	Recommended accessories	Page 21
Appendix B	HP-IB capability	Page 25

Section 1

Introduction This User's Guide is a simplified operating guide to the HP 8508A Vector Voltmeter, and is designed as an introduction to the instrument. Typical measurements are illustrated using step-by-step procedures.

More detailed operating and programming information is given in the HP 8508A Operating and Service Manual (HP part number 08508-90000).

Product description The HP 8508A Vector Voltmeter is a dual-channel, autoring receiver which measures the voltages of two CW signals and the phase difference between them. The following diagram shows the vector relationship between two signals at the same frequency and the way that one is used as a phase reference in the HP 8508A.

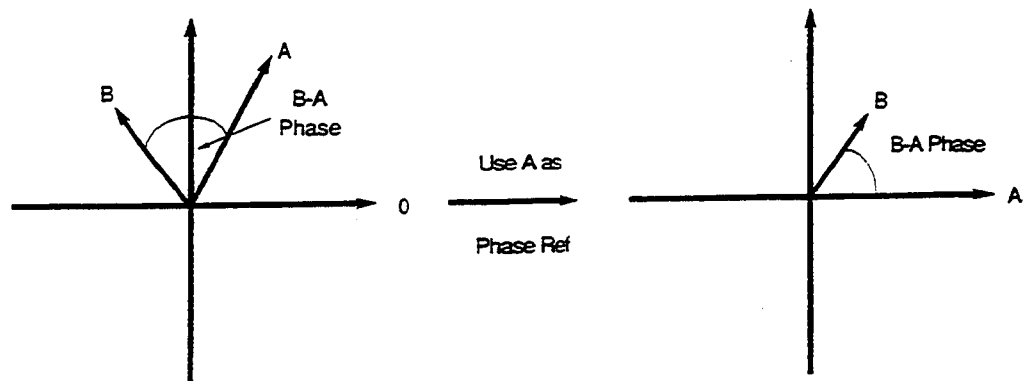

Figure 1. Vector Signals

The measurements are either of a single channel or the ratio between the two channels, and the results displayed as voltage or power (in linear or log units), normalized magnitude and phase angle, or real and imaginary components. In addition the HP 8508A has built-in procedures for simple network analysis. The HP 8508A has two configurations - the first providing two high impedance probe inputs with a frequency range from 100kHz to 1GHz, and the second providing two 50ohm type-N connector inputs with a frequency range of 300kHz to 2GHz. The configuration can be changed by replacing the instrument's input module.

Applications

The HP 8508A is used in applications where vector signal information is required at low cost - particularly in the design, manufacture or service of RF assemblies. The HP 8508A is a simple, high-sensitivity receiver and can be used with any source, including one that is part of the device to be tested. Its built-in HP-IB interface for programming allows it to be used as an economical tool in automated production environments.

Typical measurements include voltage, power, gain or loss, impedance and phase matching. Measurements can be made either from the input to the output of the device, or by probing within the device. Other measurements include transmission and reflection - procedures that include test system calibration against known standards.

Equipment required A typical setup includes a source (which may be part of the device to be tested), a reference path and a measurement path. Cables, adapters and other accessories required depend on the application. A list of common accessories for use with the HP 8508A is shown in Appendix A. The following diagram shows a typical setup.

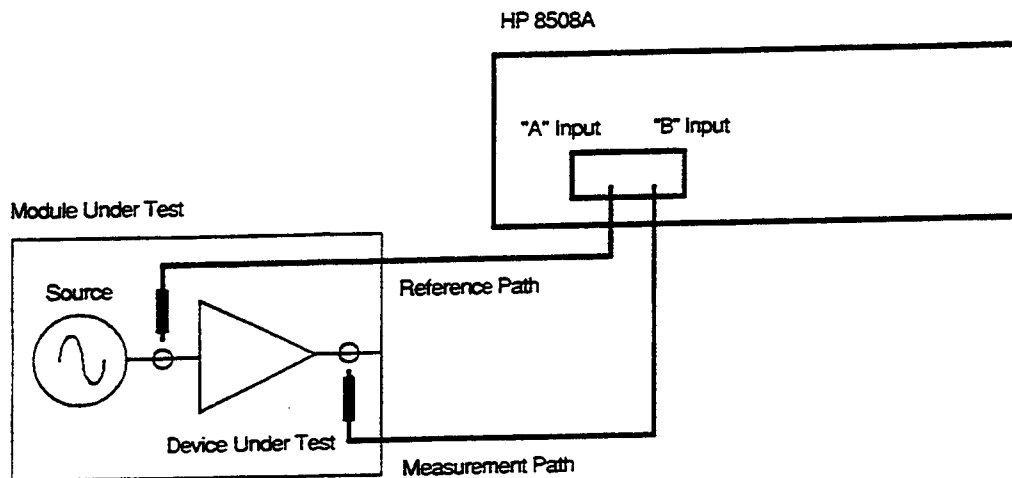

Figure 2. Typical Probing Set-up

In order for the source to be suitable for use with the HP 8508A, it has to meet certain specifications. It must produce a stable CW signal at the frequency of interest, with no modulation.

Section 2

Getting started

To introduce you to the main functions of the HP 8508A, we'll go through a few simple measurements. You will learn to make single channel voltage and power measurements and measure the vector ratio between two voltages.

Any unmodulated RF signal in the frequency range 100 kHz to 1 GHz can be used as a source for these measurements. This includes a source that is part of a larger device under test.

This diagram shows all the keys you will need to make the measurements, along with the step numbers in the example.

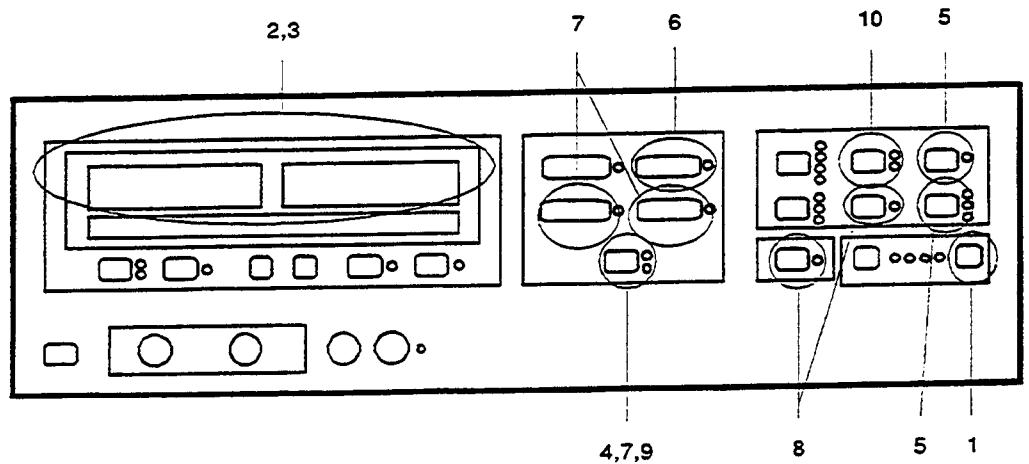

Figure 3. Front Panel

Operator's notes

In the descriptions throughout this Guide, keys on the instrument are described by writing the key name in square brackets, for example [PRESET].

Keys that have multiple selections are described by writing "select", followed by the key name in square brackets, then the required function in bold type, for example "Select [REFL MEAS] **SWR**". When you press this type of key, the next valid state will be selected. Press the key the required number of times to light the LED beside the state requested. Some selections are only available in combination with other keys, so don't worry if all the selections are not available.

Some keys have a primary and alternative function. The alternative function key labels appear in blue on the front panel. These functions are described by showing [SHIFT] then the function name (which appears in blue on the front panel) - for example, the "Save Reference" function is described as press [SHIFT] then [SAVE REF]. Instrument functions do not display "OFF" or "AUTO". These modes are selected when no other indication appears.

1. PRESET Before beginning a new measurement, press [PRESET] to return the HP 8508A to a known state. The following list shows the preset condition:

MEASUREMENTS	FUNCTIONS
MEASUREMENTS A.....ON	REF.....OFF
DISPLAY 1.....UNITS	FORMAT.....MAG, ANGLE
	REFL MEAS.....OFF
DISPLAYS	REF SELECT.....OFF
METER SELECT.....OFF	POWER MEAS.....OFF
LOCK RANGE.....AUTO	SYSTEM IMPD.....50 ohm
MAG RANGE.....AUTO	
HOLD VALUE.....OFF	
DISPLAY 1.....mV	
DISPLAY 2.....blank	

2. UNLOCKED INDICATOR Check that there is no input to the probes. With no input signal, the A UNLOCKED indicator should be ON and DISPLAY 1 (the left display) should indicate underrange (---).

NOTE: If there are high level radiated signals present, DISPLAY 1 may give a reading. This reading is caused by the un-terminated probe acting as an antenna. It will not affect the instrument's ability to make measurements on your circuit.

3. SINGLE-CHANNEL MEASUREMENT - A The A probe is used as a reference by the HP 8508A, and must be connected for the instrument to function. The signal level should be around 100mV.

Connect the A probe to the source and turn on the output. The A UNLOCKED indicator should go OFF and DISPLAY 1 should show the source output voltage.

4. VOLTAGE UNITS Select [DISPLAY] dB to have the HP 8508A compute and display the voltage in dBμV.

5. POWER MEASUREMENT Press [POWER MEAS] to display power in dBm in a 50ohm system. The conversion of voltage to power uses the value set with the [SYSTEM IMPD] key, the default value being 50 ohms.

Press [POWER MEAS] again to return to the voltage measurement mode.

6. SINGLE-CHANNEL MEASUREMENT - B Most measurements with the HP 8508A will be done using the B probe, leaving the A probe in place as a reference. The B channel is much more sensitive since the A channel already provides the signal to which the instrument is locked.

Press [B] to display the B input voltage in Display 2. (The A reading remains in Display 1 unless you turn it off by pressing the [A] key. The A probe must still be connected in order to keep the instrument locked.) Display 2 shows the B channel residual noise level - less than $10\mu\text{V}$ when the probe is terminated, with no signal input.

7. DUAL-CHANNEL MEASUREMENT The HP 8508A can display the ratio of the signals in its two channels.

Connect the two probes to the source output using a tee, as shown in the following diagram.

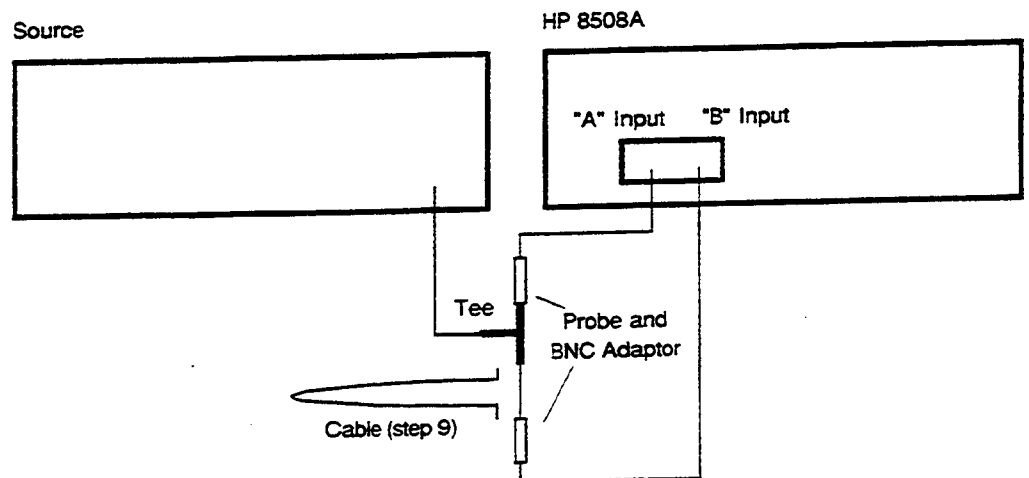

Figure 4. Two Probe Connection

Select [DISPLAY] UNITS to display the levels as voltages. (The A and B voltages in Displays 1 and 2 respectively should read approximately the same value.) Press [B/A MAG] to show the voltage ratio of B to A in Display 1. The reading should be approximately 1.0. Press [B-A PHASE] to display the input phase difference in Display 2. The reading should be approximately 0 deg.

- 8. SET A REFERENCE** Press [SHIFT] then [SAVE REF] to store the current measurement as a reference and normalize readings to the saved reference value. The displays should now read exactly 1.0 magnitude, and 0.0 deg phase.

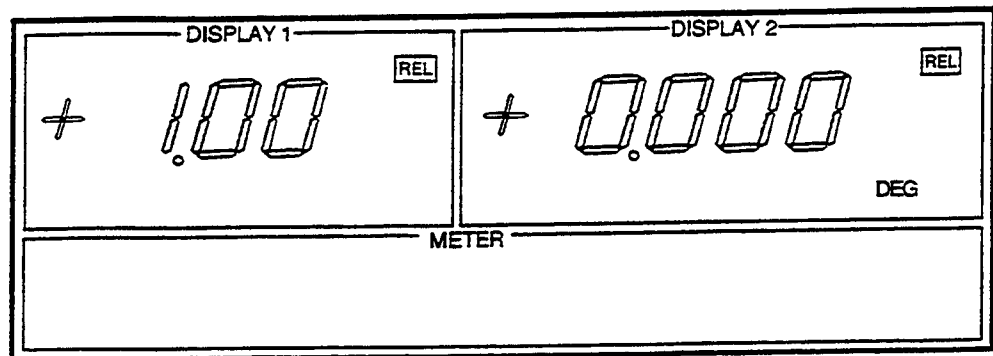

Figure 5. Displays

- 9. RELATIVEMEASUREMENT** Now insert the cable as shown in Figure 4. The readings are now of the voltage ratio and phase difference caused by the cable, using the reference set in step 8. Select [DISPLAY] dB to read the cable insertion loss in dB. The phase difference can be used to calculate the cable's electrical length.

- 10. REALANDIMAGINARY** Instead of magnitude and phase, you can show the measurement results as real and imaginary components. Select [FORMAT] REAL & IMAG to see results in this form.

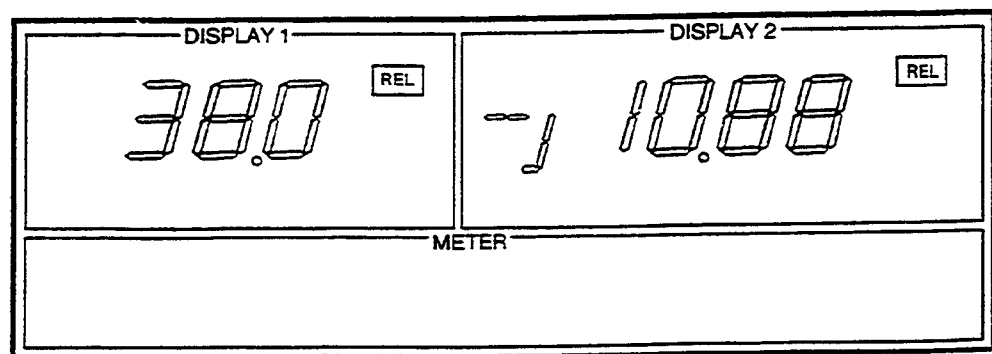

Figure 6. Displays

You've made voltage measurements (A and B) and a vector ratio measurement (B/A MAG, B-A PHASE), and normalized the ratio to a reference. Now go on to explore some more uses of the HP 8508A in the next section.

Section 3

Basic measurements

a. Measurements with probes

For this section, let's take an example of making measurements on a printed circuit board buffer amplifier. It is part of a 50MHz source assembly, and has a gain of approximately 14dB.

Probing at the input of the amplifier (the output of the oscillator) will allow us to find a reference signal and probing at the output of the amplifier will give the amplifier gain. We'll use the integral source as the stimulus, so the amplifier will be tested under normal operating conditions.

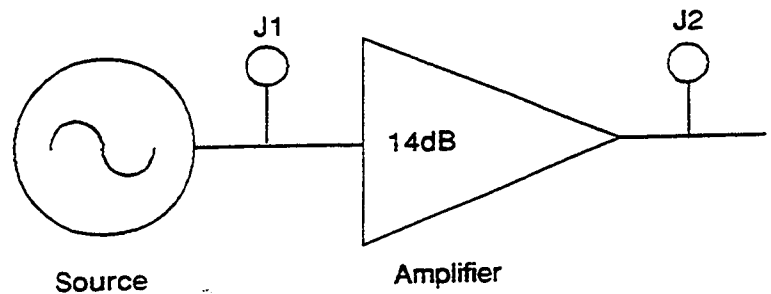

Figure 7. Test Assembly With Measurement Points

Since the circuit impedance is 50 ohms, and the measurements are at relatively low frequencies, we can neglect the loading effects of the probe tips on the circuit response. For more sensitive applications, the HP 11576A 10:1 Divider or HP 10216A Isolator accessories can be used with the probes to minimize loading effects and hence reduce measurement errors.

Measurement details

1. Connect both probes at point "J1" (the amplifier input) in the circuit. Press [PRESET] to return the HP 8508A to a known starting state.
2. Check that the circuit under test is powered up and that the HP 8508A A UNLOCKED indicator is off. Press [B/A MAG] and [B-A PHASE] to display vector ratio.
3. Select [DISPLAY] dB to measure the amplifier's gain as a log ratio. Press [SHIFT] then [SAVE REF] to store the reference and set the ratio displays to magnitude 0.0dB and phase 0 degrees.
4. Move the B probe to point "J2" (the amplifier output) and measure the gain and phase change. Change the frequency of the oscillator over its operating range and check the frequency response variation. In a circuit with adjustable gain, the HP 8508A METER display is an aid to tuning. (Use of the meter display is covered in the next example.)

b. Measurements in a 50 ohm system

50 ohm measurements can be made directly when the HP 8508A is fitted with the type-N HP 85082A Input Module, or by using adapters with the probes of the HP 85081A Input Module. HP 11536A Probe Tees are available separately or as part of the HP 11570A Accessory Kit. The following diagram shows how to connect the probe adapters to make 50 ohm measurements.

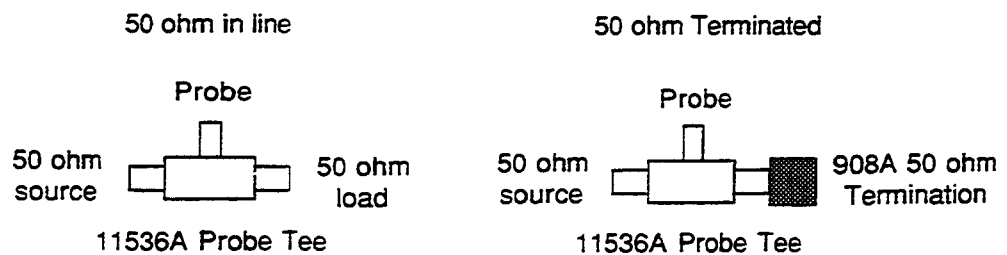

Figure 8. Probe to 50ohm Options

In this example, we'll measure the 3dB point of a low-pass filter that cuts off at around 50MHz. The circuit includes a source, and a power splitter which we'll use to obtain a reference signal. The filter is preceded by a 6dB pad to minimize out-of-band reflection problems.

Measurement details

1. Connect the equipment as shown below. Press [PRESET] to get the instrument to a known state, then [B] to measure the filter output.

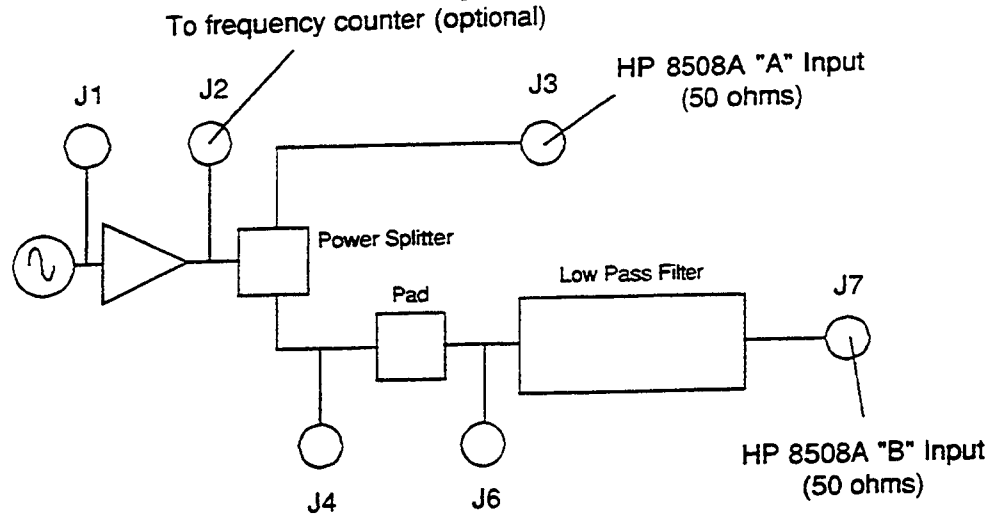

Figure 9. Test Set-up

2. Select [METER SELECT] DISP2 to activate the bar on the B voltage, then tune the source frequency for a maximum to set the source in the filter passband.

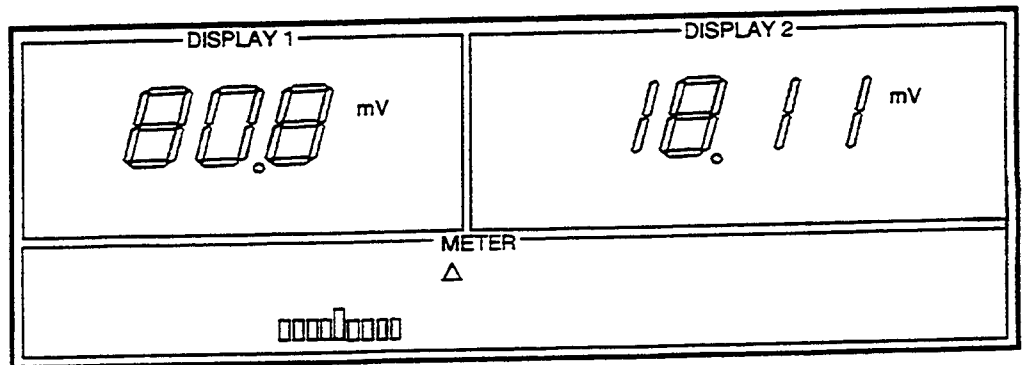

Figure 10. Meter Display

3. Press [B/A MAG] to measure the amplitude ratio, and select [DISPLAY] dB to display a log ratio.
4. Press [SHIFT] then [SAVE REF] to store the current reading, zero the magnitude reading and refer future measurements to the filter passband.
5. Now increase the source frequency until the display reads -3dB. Note the source frequency. This is the filter 3dB cutoff frequency.

Section 4

Advanced measurements

In this section we'll cover some simple network analysis measurements using the HP 8508A and a companion source. We'll cover both transmission and reflection measurements to show how some of the intelligence of the HP 8508A can be used to make your measurements easier. The measurement examples will use 50 ohm devices - refer to Section 3b "Measurements in a 50 ohm system" for details of configuring the HP 8508A for 50 ohm inputs.

a. Transmission

One good use of a CW receiver such as the HP 8508A is in the measurement of gain as a function of input level. The HP 8508A can display B/A as a ratio, so effects caused by changing input level can be seen directly.

To illustrate this we'll measure the 1dB gain compression point of a 50MHz, 14dB gain amplifier. Since the output at gain compression is specified to be 10dBm, we'll use an HP 8491A 10dB attenuator at the output of the amplifier to minimize measurement errors due to high signal levels.

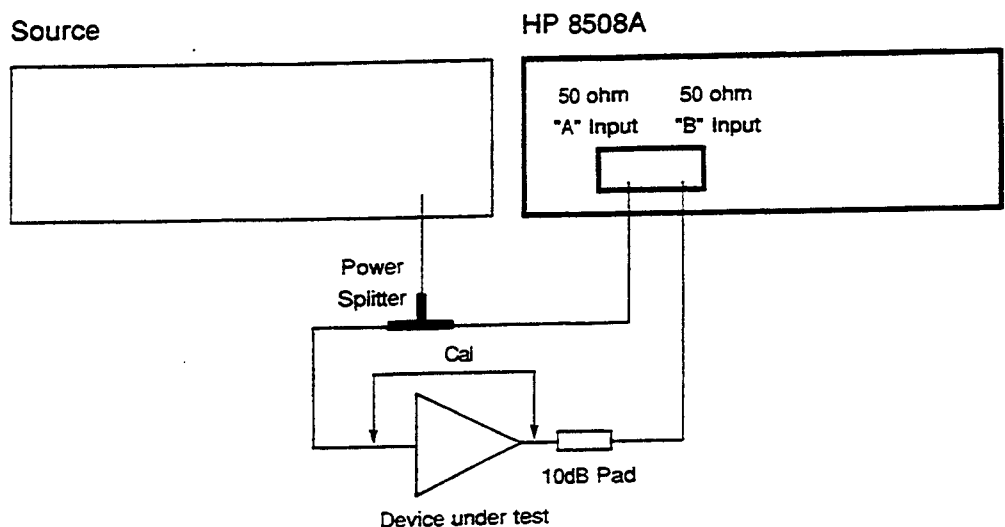

Figure 11. Transmission Test Set-up

1. Connect the A and B inputs to the power splitter. Set the source output level in the normal operating range of the amplifier. Set the source output frequency to 50MHz. Press [PRESET] to return the HP 8508A to a known state.

2. Press [B/A MAG] to measure the magnitude ratio. Select [DISPLAY] dB to measure log gain. Press [SHIFT] then [SAVE REF] to store the current measurement, zero the display and remove splitter and input effects.

3. Connect the amplifier between the splitter and the B input and measure and note the gain.

4. Press [SHIFT] then [SAVE REF] to store and use this (nominal) gain as a reference and reset the reading to 0dB.

5. Increase the source output level until the HP 8508A reads -1dB. The amplifier is now operating at its gain compression point.

6. Press [REF] to remove the reference offset. Press [A] to measure the input voltage (dBμV), and [POWER MEAS] to convert the reading to dBm. Since the splitter is symmetrical, the measured power at the A input will be the same as at the amplifier input to within the tracking specifications of the power splitter.

b. Reflection The measurement of small reflections in high frequency RF systems requires careful consideration. At low levels, reflections from the device under test can be masked by leakage signals in the measuring equipment, so to make the measurement accurately, we'll need to use a high directivity reflection bridge or directional coupler. We'll use a short circuit as a calibration standard, and measure the return loss of a precision termination.

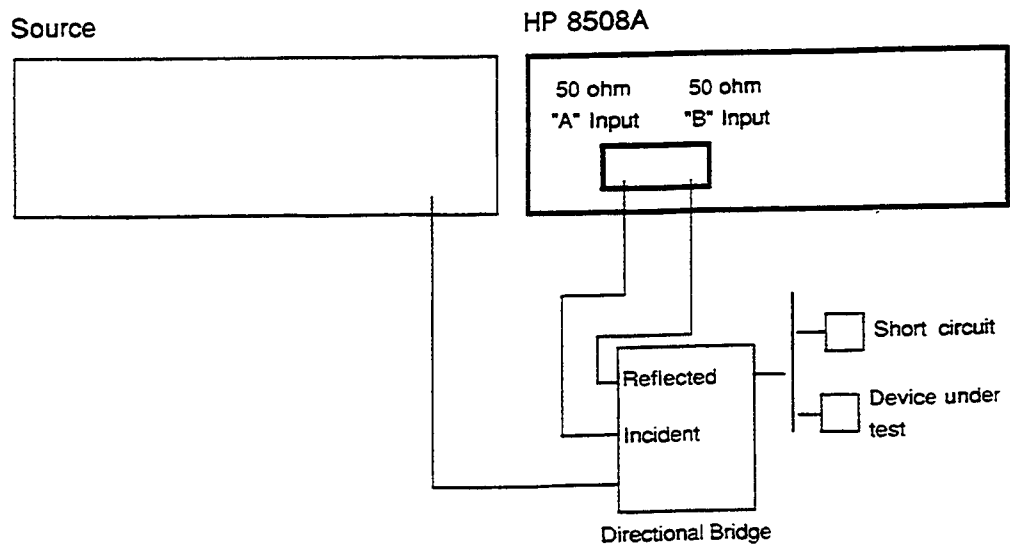

Figure 12a. Bridge Test Set-up

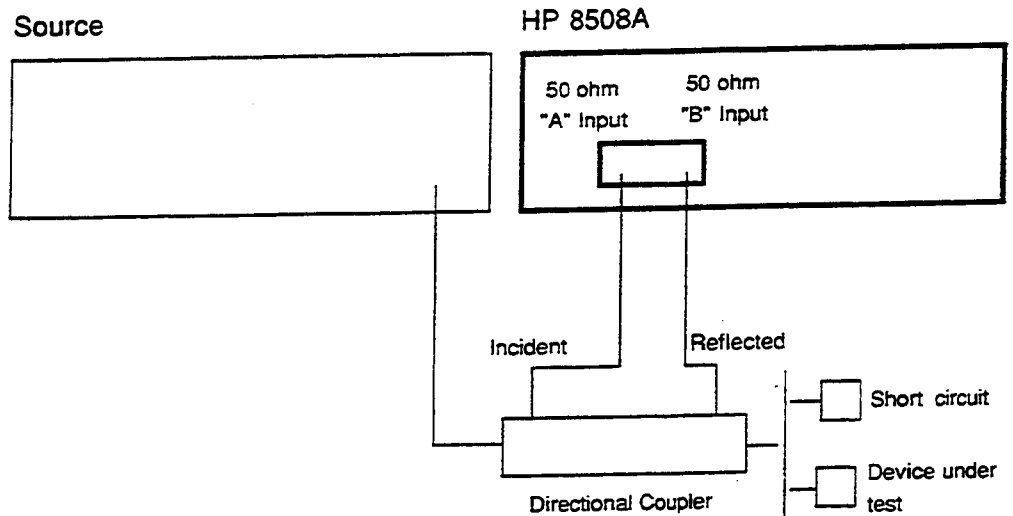

Figure 12b. Coupler Test Set-up

1. Connect the A and B inputs to the bridge or splitter as shown in one of the above diagrams (depending on the equipment you have available). Set the source power to 0dBm and frequency to the test frequency.
2. Connect a short circuit to the test port as the calibration standard. Press [PRESET] to return the HP 8508A to a known state. Select [REFL MEAS] θ , \angle to measure reflection coefficient.
3. Select [REF SELECT] SHORT to use a short circuit as the calibration standard. Select [DISPLAY] dB to measure the reflection as return loss in dB. Press [SHIFT] then [SAVE REF] to store the current measurement and display a return loss of 0dB and angle 180 degrees.
4. Remove the calibration standard and connect the termination to be measured. Read the return loss directly.

The HP 8508A has conversions built in to allow you to read results in normalized impedance for use with Smith charts. To make the conversion, select [REFL MEAS] Z, and [SYSTEM IMPD] NORM. There is no need to recalibrate since the new display is computed from the same reference measurements as before.

c. Other functions This is a short description of other functions in the HP 8508A that you will find useful. Full details are in the Operating Manual.

Key	Function	Use
[HOLD VALUE]	Freeze display at last reading when signal disappears.	Circuit probing, especially on dense circuits where the probe can easily slip to another track.
[REF SELECT] LOAD	Use a termination as the calibration standard for reflection measurements.	Allows the use of a simple tee to make approximate reflection measurements at frequencies up to 100MHz.
[LOCK RANGE]	Overrides automatic selection of frequency lock range.	Faster lock in automatic systems and to ensure the same state when making repetitive measurements near a range boundary.
[MAG RANGE]	Overrides automatic selection of magnitude display range.	To eliminate excess display resolution and to control the rear panel output range when using auxiliary equipment.
[CAL TEST]	Control test output and perform internal calibration.	To allow an operator to optimize instrument performance and to control the test output when performing confidence tests.
[DIR ANLG OUT]	Lock instrument state.	Fast response using rear panel outputs for narrowband sweeps.
[SHIFT][DELAY]	Converts phase difference to delay.	Allows single point measurements of delay.

Section 5

Automatic measurements This section of the User's Guide is designed to introduce you to the remote operation of the HP 8508A. All the functions of the HP 8508A, with the exception of the LINE switch, can be operated remotely. Appendix A has details of all the programming commands and results formats.

The BASIC language programming example below demonstrates the use of the HP 8508A in a simple stimulus response measurement system. The program uses an HP 9000 Series 300 Computer and BASIC 4.0 (or later) language system. The source commands shown are for the HP 8657A Synthesized Signal Generator.

1. Connect the equipment as shown in the diagram below. Switch on all the equipment except the computer.

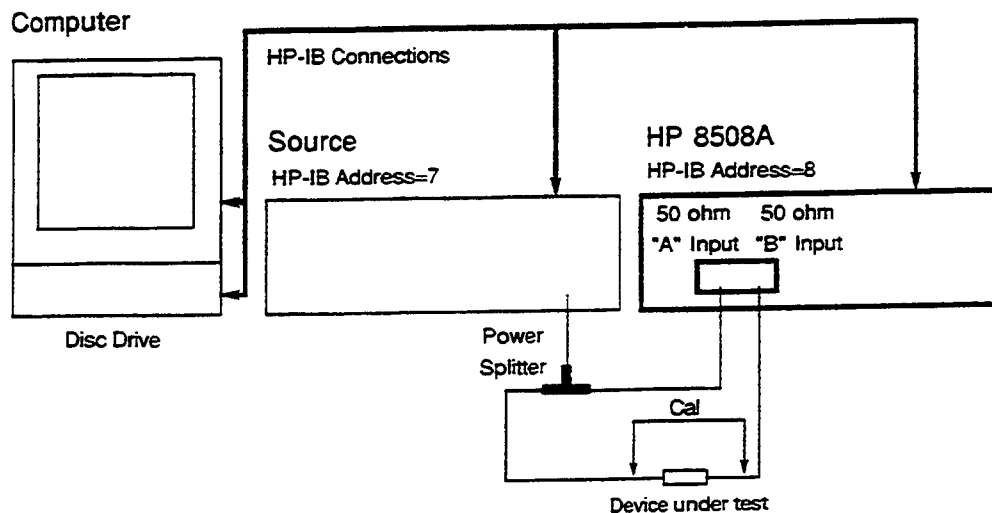

Figure 13. Automatic Test Set-up

2. On the HP 8508A, press [SHIFT] then [ADDRESS] to display the HP-IB address. The program assumes that the address is set to 8. If the address is different, use the STEP keys to reset it.
3. On the HP 8657A, press [SHIFT] then [ADRS] to display the HP-IB address. The programs throughout this section assume that the address is set to 7. If the address is different, use the DATA ENTRY keys to reset it.

4. Switch on the computer and load the BASIC language SYSTEM. For more information on the computer language system, consult the computer and language operating manuals. Load the following binaries:

HPIB CS80 ERR IO GRAPH

Note: If you are using an HP 9121 single-sided disc drive, load driver "DISC" instead of "CS80".

5. Type in the program contained in Program listing. It describes a complete measurement - a first run to characterize the system response and a second with the device in place to make measurements and plot the results on the computer screen.

6. Run the program. Connect the calibration path when requested and press the CONTINUE softkey on the computer. The magnitude and phase data is stored to be summed with the measurement data later. When the program pauses, insert the device and press the CONTINUE softkey to make the measurement. The results are plotted on the computer screen.

Program Explanation

Lines 10 to 100: Assign array variables, fix start, stop and step frequencies (in MHz) and source power level in dBm. Declare I/O paths to the instruments. Set angle units to degrees and turn off graphics display.

Lines 120 to 210: Measurement control and operator interface.

Line 220: Switch off source output after test.

Lines 240 and 250: Plot axes and results.

Lines 310 to 390: Step generator and receiver - measure system response and store data.

Lines 410 to 480: Measure device response and add to calibration run data.

Lines 540 to 590: Define initial setup of HP 8508A. The measurement is configured and will be executed on receipt of a "trigger" command.

Lines 610 to 630: Define initial setup of source. The source is set to minimum output power and all modulation is turned off.

Lines 650 to 690: Set source frequency and power.

Lines 710 to 750: Trigger HP 8508A and take results.

Lines 770 to 950: Draw and label axes on the computer screen.

Lines 970 to 1070: Plot magnitude and phase responses.

Program listing

```

10 DIM Freq(50),Mag_cal(50),Phase_cal(50),Mag(50),Phase(50)
20 Fstart=10
30 Fstop=100
40 Fstep=10
50 No_of_steps=INT((Fstop-Fstart)/Fstep)
60 Power=0
70 ASSIGN @Vvm TO 708
80 ASSIGN @Siggen to 707
90 DEG
100 GRAPHICS OFF
110!
120 DISP "Connect for calibration - press CONTINUE when ready"
130 PAUSE
140 DISP "Measuring - calibration run"
150 GOSUB Cal_run
160!
170 DISP "Connect device - press CONTINUE when ready"
180 PAUSE
190 DISP "Measuring - dut run"
200 GOSUB Meas_run
210 DISP ""
220 CALL Init_siggen(@Siggen)
230!
240 CALL Draw_axes(Fstart,Fstop,Fstep,No_of_steps)
250 CALL Plot_results(No_of_steps,Freq(*),Mag(*),Phase(*))
260!
270 STOP
280!
290! ***** Subroutines *****
300!
310 Cal_run: !
320 CALL Init_siggen(@Siggen)
330 CALL Setup_vvm(@Vvm)
340 FOR Point=0 TO No_of_steps
350 Freq(Point)=Fstart+Point*Fstep
360 CALL Set_siggen(@Siggen,Freq(Point),Power)
370 CALL Measure(@Vvm,Mag_cal(Point),Phase_cal(Point))
380 NEXT Point
390 RETURN
400!
410 Meas_run: !
420 FOR Point=0 TO No_of_steps
430 CALL Set_siggen(@Siggen,Freq(Point),Power)
440 CALL Measure(@Vvm,Mag_meas,Phase_meas)
450 Mag(Point)=Mag_meas-Mag_cal(Point)
460 Phase(Point)=Phase_meas-Phase_cal(Point)
470 NEXT Point
480 RETURN
490!
500 END
510!

520! ***** Subprograms *****
530!
540 SUB Setup_vvm(@Vvm)
550 CLEAR @Vvm
560 OUTPUT @Vvm:"TRIGGER:SOURCE BUS"
570 OUTPUT @Vvm:"FORMAT LOG"
580 OUTPUT @Vvm:"SENSE TRANSMISSION"
590 SUBEND
600!
610 SUB Init_Siggen(@Siggen)
620 OUTPUT @Siggen:"AP-127DM AOODB AM S4 FM S4 RP"
630 SUBEND
640!
650 SUB Set_siggen(@Siggen,Freq_Level)
660 IMAGE "FR".K."MZ AP".K."DM"
670 OUTPUT @Siggen USING 660:Freq_Level
680 WAIT .120
690 SUBEND
700!
710 SUB Measure(@Vvm,Mag_meas,Phase_meas)
720 TRIGGER @Vvm
730 OUTPUT @Vvm: "FETCH?"
740 ENTER @Vvm:Mag_meas,Phase_meas
750 SUBEND
760!
770 SUB Draw_axes(Fstart,Fstop,Fstep,No_of_steps)
780 GRAPHICS OFF
790 GINIT
800 CSIZE=3
810 WINDOW Fstart-Fstep,Fstop+.5*Fstep,-350,200
820 CLIP Fstart,Fstop,-180,180
830 AXES Fstep,20,Fstart,0
840 CLIP Fstart-Fstep,Fstop+.5*Fstep,-280,200
850 MOVE Fstart-.5*Fstep,-150
860 LDIR 90
870 LABEL "Mag (10dB/div), phase (20deg/div)"
880 MOVE (Fstart+Fstop)/2-Fstep,-200
890 LDIR 0
900 LABEL "Frequency (MHz)"
910 FOR Freq=Fstart+Fstep TO Fstop STEP Fstep
920 MOVE Freq-.03*No_of_steps*Fstep,-25
930 LABEL Freq
940 NEXT Freq
950 SUBEND
960!
970 SUB Plot_results(No_of_steps,Freq(*),Mag(*),Phase(*))
980 GRAPHICS ON
990 For Point=1 to No_of_steps
1000 LINE TYPE 1
1010 MOVE Freq(Point-1),2*Mag(Point-1)
1020 DRAW Freq(Point),2*Mag(Point)
1030 LINE TYPE 4
1040 MOVE Freq(Point-1),Phase(Point-1)
1050 DRAW Freq(Point),Phase(Point)
1060 NEXT Point
1070 SUBEND

```

Changing the program You can change the frequency range and step size by changing the variables in lines 20 to 40. If the number of points exceeds 51, you'll need to increase the size of the data storage arrays to suit. To measure a number of devices using a single calibration run, just add a loop back to the instruction for connecting the device after plotting is complete. To make return loss measurements, use a reflection test set in place of the power splitter - no change to the program is required if you use a short circuit as the calibration device.

Appendix A

Recommended accessories

Probing adapters	Description	Freq. range	Use
	10:1 Divider HP 11576A	dc to 100MHz	For measuring high level signals with probes, and for reducing loading effects on sensitive circuits.
	Isolator HP 10216A	dc to 1GHz	Reduce phase error due to changing test point impedance.
	Probe Tee HP 11536A	dc to 1GHz	Adapts probes for in-line measurements in 50 ohm systems.
	BNC Adapter HP 10218A	dc to 1GHz	Converts probe tip to BNC (m) connector.
	Spanner Tip Assy HP 5060-0549		Probe tip protector and ground lead.

50 ohm measurement accessories

HP Model	Freq. range	Description
Power Splitter HP 11552-60009	0.1 to 110MHz	2 way, 2 resistor splitter for ratio measurements.
Power Splitter HP 11549A	dc to 1GHz	2 way, 2 resistor splitter for ratio measurements.
Power Splitter HP 11850C	dc to 3GHz	3 way, 3 resistor splitter for ratio measurements.
Directional Bridge HP 8721A	dc to 110MHz	Directional splitter/combiner for reflection measurements.
Directional Coupler HP 778D	100MHz to 2GHz	Dual directional coupler for reflection measurements.
Directional Coupler HP 774D	215MHz to 450MHz	Reduced frequency range dual directional coupler.
Directional Coupler HP 775D	450MHz to 940MHz	Reduced frequency range dual directional coupler.
Directional coupler HP 776D	940MHz to 1.9GHz	Reduced frequency range dual directional coupler.
Transmission/ Reflection Test Set HP 85044A	300kHz to 3GHz	Combined splitter and reflection bridge. Test port APC-7

HP Model	Freq. range	Description
Termination HP 908A	dc to GHz	50 ohm Termination, type-N (m).
N(m) to N(m) Adapter HP 1250-1475		
N(f) to N(f) Adapter HP 1250-1472		
APC-7 to N(f) Adapter HP 11524A		
APC-7 to N(m) Adapter HP 11525A		

75 ohm measurement accessories

HP Model	Freq. range	Description
Directional Bridge HP 8721A opt 008	dc to 110MHz	Directional splitter/combiner for reflection measurements.
Transmission/ Reflection Test Set HP 85044B	300kHz to 2GHz	Combined splitter and reflection bridge. Inputs 50 ohm test port 75ohm type-N (f). There are 1 each HP 11852A Minimum Loss Pads supplied.
Minimum Loss Pad HP 11852B	dc to 2GHz	Converts between 50 and 75 ohm impedances. Connectors 50 ohm type-N (f). 75 ohm type-N (m).
N(m) to N(m) Adapter HP 1250-1528		
N(f) to N(f) Adapter HP 1250-1529		
N(m) to BNC(f) Adapter HP 1250-1535		

Appendix B

HP-IB capability Here's a brief description of the HP-IB programming capability. For more detailed information, consult IEEE standard 488-1987.

Identification	Function	Capability
SH1	Source Handshake	Complete.
AH1	Acceptor Handshake	Complete.
T6	Talker	Basic talker. serial poll. no Talk Only. Unaddress if MLA.
TE0	Extended Talker	None.
L4	Listener	Basic listener. no Listen Only. Unaddress if MTA.
LE0	Extended Listener	None.
SR1	Service Request	Complete.
RL1	Remote Local	Complete.
PP0	Parallel Poll	None.
DC1	Device Clear	Complete.
DT1	Device Trigger	Complete.
C0	Controller	None.

HP-IB Results Formats Data returned by the HP 8508A from measurement results is always in the form

`<+>/<->D.DDDE<+>/<->DD<term>`

and is always in fundamental units (volts, ohms, watts, etc.).

The terminator `<term>` depends on the data requested, as follows:

- `<term>` is a comma (,) where another data item follows as part of the same result.
- `<term>` is a semicolon (;) where the data item completes a result and another result follows.
- `<term>` is a carriage-return, linefeed `<cr>`,`<lf>` where the data item is the last or only part of a result.

HP-IB Command Set The HP-IB commands used in the HP 8508A conform to the standards set by document IEEE 488.2-1987, "Codes, Formats, Protocols and Common Commands for use with ANSI/IEEE Std 488.1, 22 January 1987".

For full details on the use of the commands, consult the Operating and Service Manual and the standards documents. The Command Set table gives a list of the commands.

Command Set

Command Set	Description	Query (1)	Command Header (2)	Parameter (3)
	Averaging Value	y	AVERAge:COUNT	<nrf>
	Capability	y	CAPability?	
	Clear Status	n	*CLS	
	Configure Measurement	n	SENSE	<meas>{,<meas>}(4)
	Correction		CORRection	
			:DATA	
	Normalize A	y	:A	<nrf>
	Normalize B	y	:B	<nrf>
	Normalize Phase	y	:PHASe	<nrf>
	Normalize Impedance	y	:IMPedance	ON OFF 1 10
	Termination	y	:TERMination	SHORT OPEN Z0
	Perform Normalization	n	:PERForm	
	Normalization State	y	:STATe	ON OFF 1 10
	Direct Analog Output	y	DANalog	ON OFF 1 10
	Display State	y	DISPlay :STATe	ON OFF 1 10
	Fetch Results	y	FETCh?	
	Continuous readings	y	:CONTinuous	
	Format	y	FORMat	LINEar LOGarithmic POLar RECTangular CARTesian
	Frequency		FREQUency	
	Band	y	:BAND	<nrf>
	Auto Ranging	y	:AUTO	ON OFF 1 10
	Identification	y	*IDN?	
	Input		INPut	
	Impedance	y	:IMPedance	<nrf>
	Module Type	y	:POD?	
	Measure	y	MEASure?	<meas>{,<meas>}(4)
	Operation Complete	y	*OPC	
	Reset	n	*RST	
	Self Test	y	*TST?	
	Service Request Enable	y	*SRE	<nrf>
	Standard Event Enable	y	*ESE	
	Standard Event Register	y	*ESR?	<nrf>
	Status Byte Request	y	*STB?	
	Status Control		STATus	
	Operation Status			
	Register		:OPERation	
	Event Register	y	:EVENt?	(7)
	Condition Register	y	:CONDition?	(7)
	Enable Mask	y	:ENABle	<nrf>(7)
	Positive Transition			
	Filter	y	:PTRansition	<nrf>(7)
	Negative Transition			
	Filter	y	:NTRansition	<nrf>(7)
	System		SYSTEM	
	Error Register	y	:ERRor?	NUMeric STRing
	Key	y	:KEY	<nrf>
	Trigger	n	*TRG	
	Trigger Setup		TRIGger	
	Source	y	:SOURce	BUS FREErun
	Wait-to-continue	n	*WAI	

NOTES

- (1) Commands that allow a query option are indicated by “y”. Commands where the query is mandatory are shown with the query question mark in the Command Header column in addition.
- (2) Letters in CAPITALS are required. The remainder of the command can be added if desired for legibility. Commands can be sent either in upper or lower case.

(3) <nrf> indicates Numeric Real Format

(4) <meas> indicates AVOLtage|BVOLtage|APOWER|BPOWER|BA|PHASe|TRANSMission|
GDELay|SWR|RHO|Y|Z|CORE

(5) Status Byte bit usage is as follows:

- bit 4 Message Available
- bit 5 Standard Even Status Register summary bit
- bit 6 Request for Service
- bit 7 Operation Status Register summary bit

Other bits unused.

(6) Standard Event Register bit usage is as follows:

- bit 0 Operation Complete
- bit 2 Query Error
- bit 3 Self-test Error
- bit 4 Execution Error
- bit 5 Command Error

Other bits unused.

(7) Operation Status Register bit usage is as follows:

- bit 0 Calibrating
- bit 2 Ranging (unlocked)
- bit 4 Measuring
- bit 5 Awaiting Trigger

Other bits unused.

For more information, call your local HP sales office listed in your telephone directory, or an HP regional office listed below for the location of your nearest sales office.

United States:

Hewlett-Packard Company
4 Choke Cherry Road
Rockville, MD 20850
(301) 670-4300

Hewlett-Packard Company

5201 Tollview Dr.
Rolling Meadows, IL 60008
(312) 255-9800

Hewlett-Packard Company

5161 Lankershim Blvd.
No. Hollywood, CA 91601
(818) 505-5600

Hewlett-Packard Company

2000 South Park Place
Atlanta, GA 30339
(404) 955-1500

Canada:

Hewlett-Packard Ltd.
6877 Goreway Drive
Mississauga, Ontario L4V1M8
(416) 678-9430

Australia/New Zealand:

Hewlett-Packard Australia Ltd.

31-41 Joseph Street,
Blackburn, Victoria 3130
Melbourne, Australia
(03) 895-2895

Europe/Africa/Middle East:

Hewlett-Packard Company
Central Mailing Department
P.O. Box 999
1180 AZ Amstelveens
The Netherlands
(31) 20/5479999

Far East:

Hewlett-Packard Asia Ltd.
47/F China Resources Building
26 Harbour Road, Hong Kong
(5) 833-0833

Japan:

Yokogawa-Hewlett-Packard Ltd.
29-21, Takaido-Higashi 3-chome
Suginami-ku, Tokyo 168
(03) 331-6111

Latin America:

Hewlett-Packard de Mexico,
Sp.A. de C.V.
Monte Pelvux No.111
Lomas de Chapultepec
11000 Mexico D.F., Mexico
(905) 596-7933

United Kingdom:

Hewlett-Packard Ltd.
Miller House-The Ring
Bracknell
Berkshire RG12 1XN, England
(4) 344/424898

08508-90001

